

## EG12\* ... SERIES

**SOLENOID GAS VALVES WITH 1/2" CONNECTION AND OPERATING PRESSURE UP TO 500mbar**

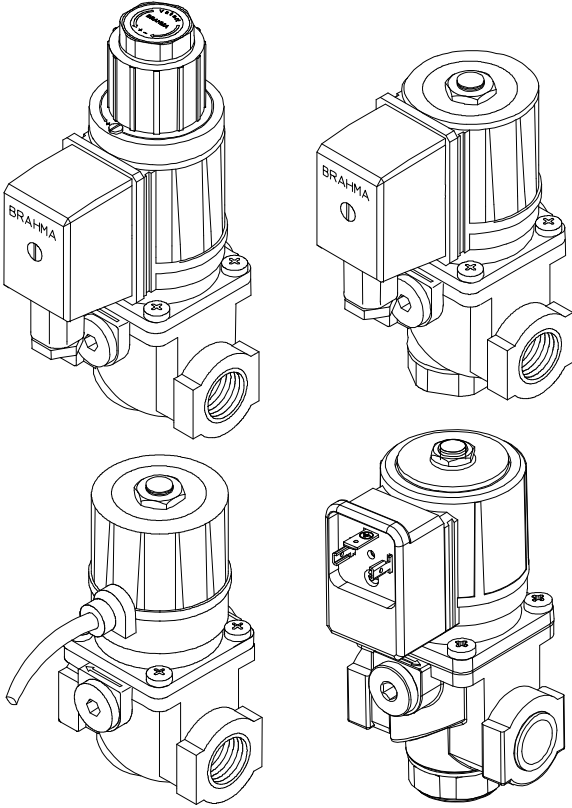

### DESCRIPTION

This series of solenoid gas valves are of normally closed type, suitable for civil and industrial applications, supplied with alternate or direct current and inclusive of a wire-net filter on the inlet to avoid the entrance of dirt of > 1 mm.

Gas valves marked with "S" or "L" after reference type have direct current supplied coil, which permitted to make actions as silent as possible.

There is the possibility to have a fast opening or a slow opening valve (obtained by special hydraulic shock-absorber), with flow adjustment and fast opening initial flow adjustment and inlet pressure plugs (all of them) or outlet plugs (excluding those with flow adjustment).

Gas valves of this series, conforming to EN161, have a CE type Certificate (CE Reg. N° 63AQ0626) in accordance to European Directives 90/396 and 93/68.

### TECHNICAL FEATURES

Class:	A
Group:	2
Supply voltage (1):	230 Vac / 50-60 Hz 110 Vac / 50-60 Hz
Operating temperature:	-10°C / +60°C
Closing time:	≤ 1s (all versions)
Opening time:	≤ 1s (quick opening versions only)
Mounting:	vertical and horizontal
Body:	die-cast aluminium
Core hitch:	PG9

(1) Versions with different supply voltages are available.

### INSTALLATION

- Respect the applicable national and European standards (e.g. EN60335-1) regarding electrical safety.
- Assemble the valve to the installation so that the arrow on the valve body has the same direction as the fuel flow.
- During the assembly of the valve to the installation piping, avoid twisting on the sheath and always use an hexagonal key to be fitted to the valve body.
- Make sure that no foreign matters have entered the valve body.
- Make sure that the max. fuel input pressure never exceeds the value appearing on the label.



## DIRECTIONS FOR EG12\*L... VALVES ADJUSTMENT

### Flow adjustment for EG12\*L...

To adjust the gas flow, you have to remove one of the two screws used to fasten the lag group (the not enamelled one, marked with 4 in Fig.1) and rotate clockwise the whole group to reduce the flow or in the opposite direction to increase it.

### Opening time adjustment

After removing the top protection, by rotating it counterclockwise, you have to act on the adjustment screw, marked with 1 in Fig.1; by rotating clockwise, the opening time becomes longer, by rotating in the opposite direction, the opening time becomes shorter.

### Quick release initial flow adjustment

After removing the top protection by rotating it counterclockwise, if you rotate clockwise the nut marked with 2 in Fig.1, the initial release will be reduced; if you rotate the same nut counterclockwise, the initial release will be increased.

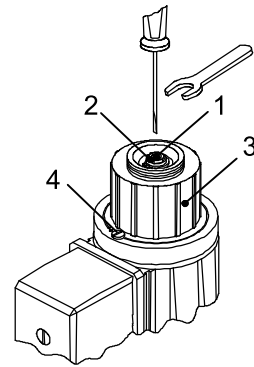

Fig. 1

## DIRECTIONS FOR EG12\*SR... AND EG12\*AR... VALVES ADJUSTMENT

### Flow adjustment for EG12\*R

After removing the bottom protection by rotating it counterclockwise, rotate clockwise the nut marked with 1 in Fig.2 to reduce the flow, rotate in the opposite direction to increase the same.

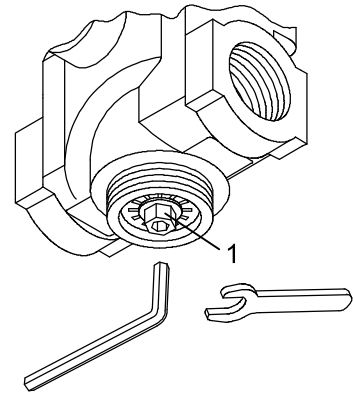
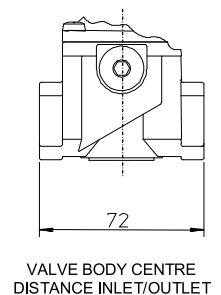
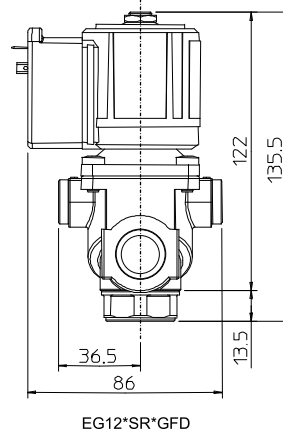
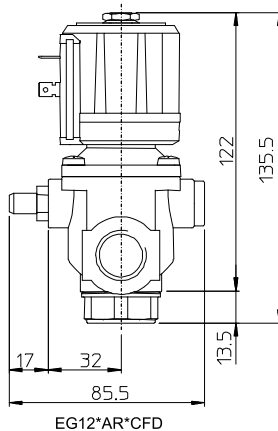
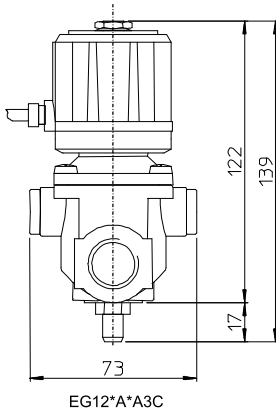
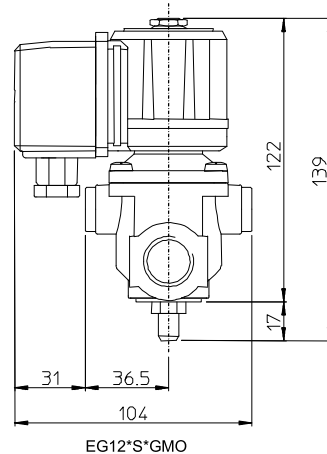
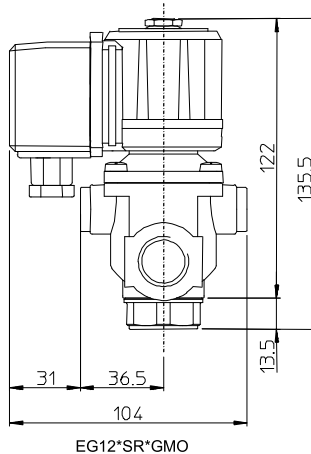
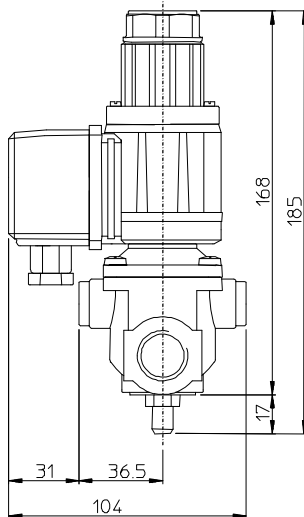

Fig. 2

## OVERALL DIMENSIONS



## DIAGRAM

PRESSURE DROP  
mbar

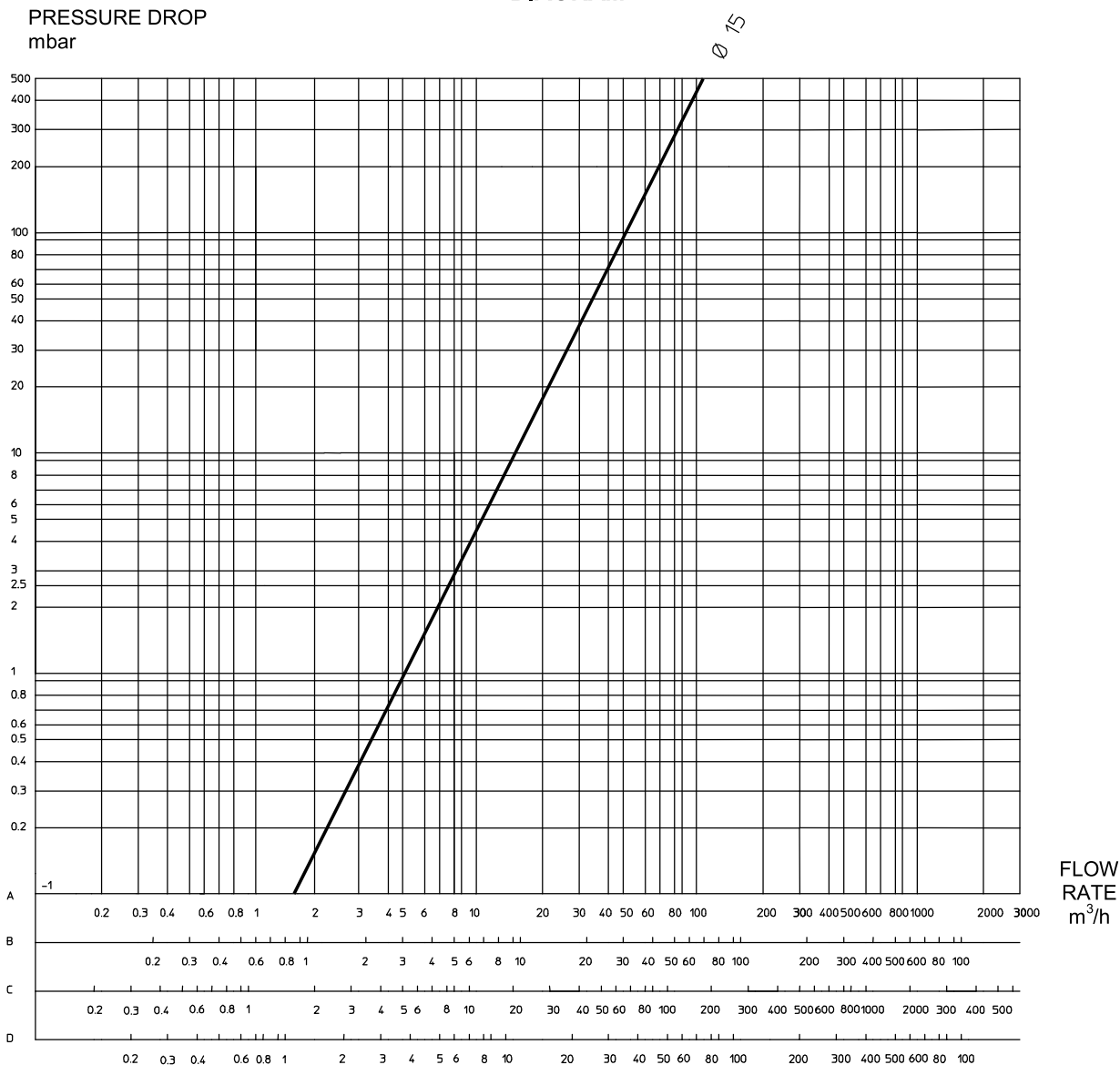

- A : Standard flow rate m<sup>3</sup>/h of NATURAL GAS relative density 0.554
- B : Standard flow rate m<sup>3</sup>/h of LPG relative density 1.54
- C : Standard flow rate m<sup>3</sup>/h of TOWN GAS relative density 0.411
- D : Standard flow rate m<sup>3</sup>/h of AIR relative density 1

### SUMMARY TABLE

Type	Operating pressure (mbar)	Orifice diameter (mm)	Connections	Weight (g)	Coil	Consumption (VA) 230Vac	Consumption (VA) 110Vac	Flow (m <sup>3</sup> /h gas with $\Delta P$ 2.5mbar)
EG12*A	0 ÷ 500	15	G1/2"	734	BE6*A3C	20	18	7,5
EG12*A	0 ÷ 500	15	G1/2"	764	BE6*AFP	20	18	7,5
EG12*A	0 ÷ 500	15	G1/2"	766	BE6*AFD	20	18	7,5
EG12*AR	0 ÷ 500	15	G1/2"	752	BE6*A3C	20	18	7,5
EG12*AR	0 ÷ 500	15	G1/2"	782	BE6*AFP	20	18	7,5
EG12*AR	0 ÷ 500	15	G1/2"	784	BE6*AFD	20	18	7,5
EG12*S	0 ÷ 500	15	G1/2"	780	BE6*C3C	20	18	7,5
EG12*S	0 ÷ 500	15	G1/2"	810	BE6*CFP	20	18	7,5
EG12*S	0 ÷ 500	15	G1/2"	812	BE6*CFD	20	18	7,5
EG12*S	0 ÷ 500	15	G1/2"	832	BE6*G..	20	18	7,5
EG12*SR	0 ÷ 500	15	G1/2"	800	BE6*C3C	20	18	7,5
EG12*SR	0 ÷ 500	15	G1/2"	830	BE6*CFP	20	18	7,5
EG12*SR	0 ÷ 500	15	G1/2"	832	BE6*CFD	20	18	7,5
EG12*SR	0 ÷ 500	15	G1/2"	851	BE6*G..	20	18	7,5
EG12*L	0 ÷ 250	15	G1/2"	935	BE6*G..	20	18	7,5